



SDO1608 SERIES



RoHS Compliant

PART NUMBERING SYSTEM

<u>SDO</u>	<u>1 6 0 8</u>	-	<u>1 R 0 M</u>	-	<u>LF</u>
TYPE	DIMENSIONS		INDUCTANCE		LEAD FREE

SHAPES AND DIMENSIONS

UNIT : mm

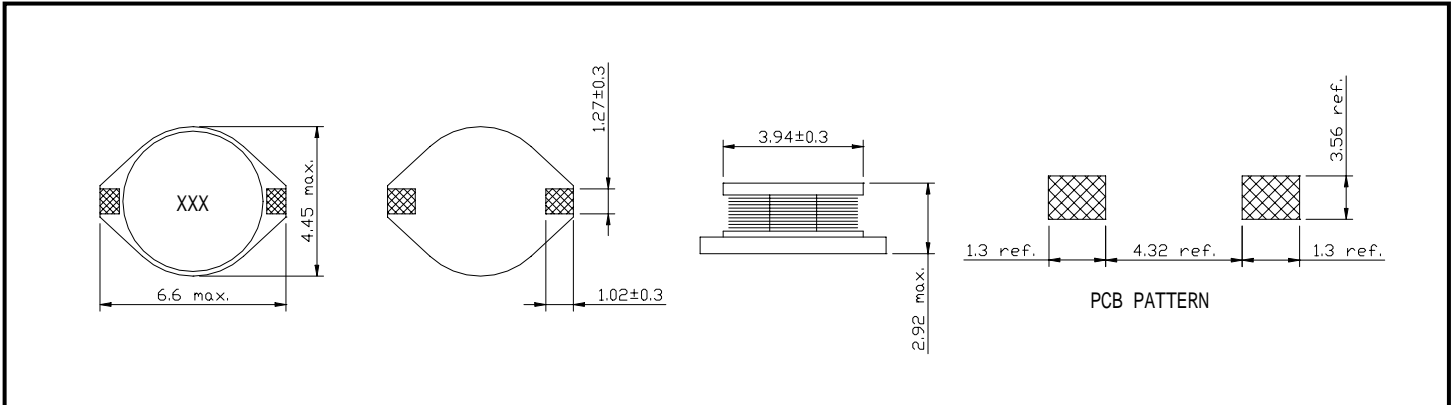



SDO1608 SERIES

SPECIFICATION TABLE

PART NUMBER	INDUCTANCE (μ H)	DCR() (Max.)	Isat (A) (Max.)	Irms (A) (Max.)	SRF(MHz) (Ref.)
SDO1608-1R0M-LF	1.0 \pm 20%	0.05	2.90	2.90	130
SDO1608-1R5M-LF	1.5 \pm 20%	0.05	2.60	2.80	115
SDO1608-2R2M-LF	2.2 \pm 20%	0.07	2.30	2.40	90
SDO1608-2R7M-LF	2.7 \pm 20%	0.08	2.10	2.10	75
SDO1608-3R3M-LF	3.3 \pm 20%	0.08	2.00	2.00	70
SDO1608-4R7M-LF	4.7 \pm 20%	0.09	1.50	1.50	50
SDO1608-6R8M-LF	6.8 \pm 20%	0.13	1.20	1.40	45
SDO1608-8R2M-LF	8.2 \pm 20%	0.16	1.15	1.30	40
SDO1608-100M-LF	10 \pm 20%	0.16	1.10	1.20	35
SDO1608-150M-LF	15 \pm 20%	0.23	0.90	1.10	30
SDO1608-220M-LF	22 \pm 20%	0.37	0.70	0.80	20
SDO1608-330M-LF	33 \pm 20%	0.51	0.58	0.60	15
SDO1608-470M-LF	47 \pm 20%	0.64	0.50	0.50	14
SDO1608-680M-LF	68 \pm 20%	0.86	0.40	0.40	11
SDO1608-101M-LF	100 \pm 20%	1.27	0.31	0.30	9
SDO1608-151M-LF	150 \pm 20%	2.00	0.27	0.25	6
SDO1608-221M-LF	220 \pm 20%	2.65	0.22	0.20	5.5
SDO1608-331M-LF	330 \pm 20%	3.80	0.18	0.16	5
SDO1608-471M-LF	470 \pm 20%	5.06	0.16	0.15	4
SDO1608-681M-LF	680 \pm 20%	9.20	0.14	0.12	3
SDO1608-102M-LF	1000 \pm 20%	13.80	0.10	0.07	2

1. Inductance is measured with a LCR meter 4284A or equivalent.
2. Inductance drop=10% typ. at rated current.
3. Operating temperature range -40 to +85
4. Electrical specifications at 25



SDO1608 SERIES

PACKAGING SPECIFICATION

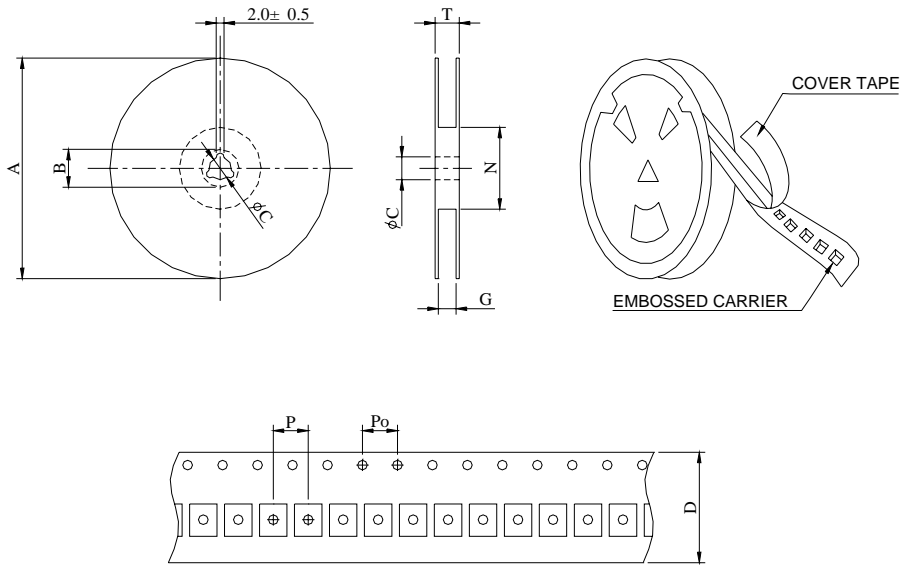

SERIES	STAYLE	Q ' TY (PCS)	DIMENSIONS (m/m)								
			A	B±0.8	C±0.5	D	G ⁺⁰	N ⁰	P	Po	T
SDO1608	13-16	2000	330	21	13	16	18	50	8	4	22.4